

## Cradle Procedure

### Ends

1. Cut the two blanks for the sides. Rip both to the same width and cut the height a little over size. Mark the middle of each part. Cut out the full sized print of the tall and short end of the cradle. Trace and cut out the arch centered on the blank. It is ok if the edges do not follow the curve. These parts will be cut off later. Sand the arch smooth. Put a 1/4" radius on the arch only of the part.
2. Cut the groove in the bottom of each end. This should be 1/4 (6.4 mm) deep. This can be done with a dado blade or router bit.
3. Mark the bottom and angles of the ends. Use a stop block to make sure the bottoms of both pieces are the same dimension. Cut using a miter saw set at 15 degrees.

### Rocker Assembly

1. Adhere pattern to blank. The top edge should be lined up with a milled edge of the board. I prefer to put blue painters tape on the wood then attaching the pattern on the tape. The pattern comes off easier this way. Mark and drill holes in the top and drill thru. Cut out the rocker on the scroll saw. If needed finish drilling the holes through using a drill.
2. Clamp the rocker to the end panel. Using a drill, drill the holes into the end panel. The hole will go into the groove.
3. Cut 1/4" (6.4 mm) dowel to 1 1/2" (38.1 mm). Glue these into the holes in the end panels. Glue and slide the rockers on the end panels. Clamp and let dry.
4. Clean out the dowels sticking into the groove with a chisel.
5. Plug open holes on the bottom of the rocker with dowels.

### Sides (version 1)

1. Cut blanks to the correct size. Using a dado stack, set it to 15 degrees and cut the groove for the bottom panel. Make sure the bottom panel fits.
2. Mark all 1/4" holes and centers of each of the arches. Drill out the arches with a 1 1/4 (31.7 mm) forstner bit. Draw tangent lines to the holes and cut out the centers. Drill the 1/4" (6.4 mm) holes almost though.
3. Rout 1/4" (6.4 mm) round over profiles on the top and bottom edges and inside cut outs.
4. Cut out grooves on both ends of the sides.

### Sides (version 2)

1. Cut blanks to the correct size. Using a dado stack, set it to 15 degrees and cut the groove for the bottom panel. Make sure the bottom panel fits.
2. Mark all 1/4" holes and drill the 1/4" (6.4 mm) holes almost though.
3. Cut out the full sized template for version 2. Trace curve on the sides.

\*\*\*IMPORTANT\*\*\*

This does require a left and right side. The template will face to the front on one and will be turned over for the left side. Make mirrored parts not matching.

4. Cut out grooves on both ends of the sides.
5. Draw a straight line from the end to the bottom of the curve, about 3 1/2 (89 mm) from the bottom. Cut out the curve.
6. Sand flat area smooth. Rout 1/4" (6.4 mm) round over profiles on the top and bottom edges.

#### Assembly

1. Cut bottom panel to size. Dry fit together to make sure everything fits.
2. Sand all parts smooth.
3. Put glue in the grooves of the sides and ends. Place all parts together and clamp together. I found it easier to elevate the cradle above the rockers.
4. While clamped, drill holes through the side panels (These holes were drilled in the side panels on step 3 or 4) about 1 1/4" (31.5 mm) deep. Insert 1/4" (6.4 mm) dowel in the holes.
5. Cut off excess dowel.
6. Sand all parts smooth, ready to finish.
7. Finish with desired finish that is child safe.

If you have any questions please feel free to contact me.



Bradly Anderson

Blog: <http://sawdustsplinters.blogspot.com/>

Etsy: [www.etsy.com/shop/AllNaturalToyPlans](http://www.etsy.com/shop/AllNaturalToyPlans)

Facebook: [www.facebook.com/organictoyplans](http://www.facebook.com/organictoyplans)

Email: [bqanderson@gmail.com](mailto:bqanderson@gmail.com)

**Cradle Version 1**

	DESCRIPTION	QUANTITY	LENGTH/DIAMETER	WIDTH	THICKNESS
A	SHORT END*	1	6 13/32	9 23/32	3/4
B	TALL END*	1	8	10 1/2	3/4
C	SIDE	2	21 1/2	5	1/2
D	ASSEMBLY DOWELS	16	1/4	1 1/4	3/4
E	ROCKER	2	10 1/2	2 1/2	3/4
F	BOTTOM	1	20 1/2	7 1/16	1/4

\* CUT THE BLANK WIDTH ON BOTH OF THESE PARTS THE SAME

**Cradle Version 2**

	DESCRIPTION	QUANTITY	LENGTH/DIAMETER	WIDTH	THICKNESS
A	SHORT END*	1	6 13/32	9 23/32	3/4
B	TALL END*	1	8	10 1/2	3/4
C	SIDE LEFT	1	21 1/2	5 1/2	1/2
C	SIDE RIGHT	1	21 1/2	5 1/2	1/2
D	ASSEMBLY DOWELS	14	1/4	1 1/4	3/4
E	ROCKER	2	10 1/2	2 1/2	3/4
F	BOTTOM	1	20 1/2	7 1/16	1/4

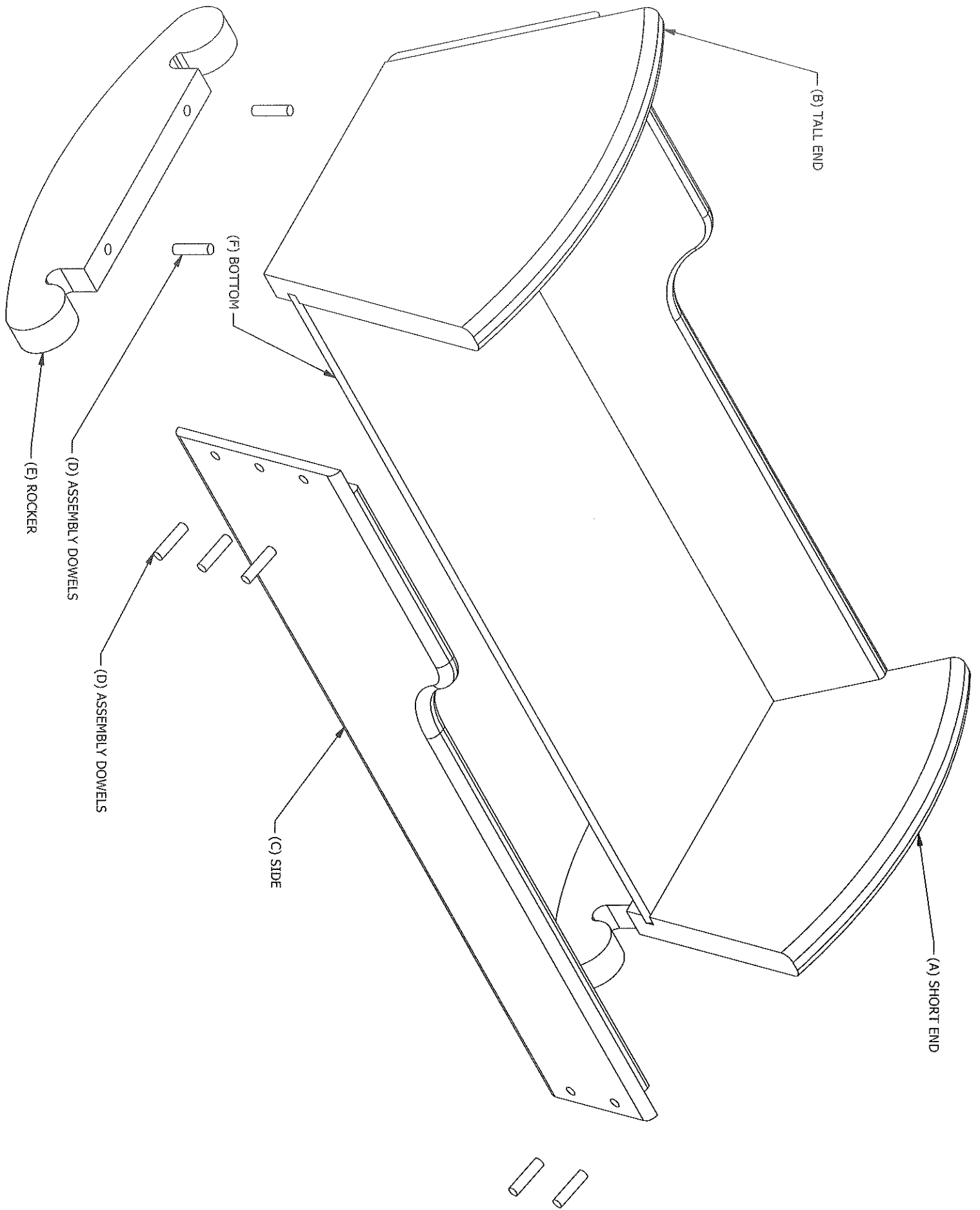

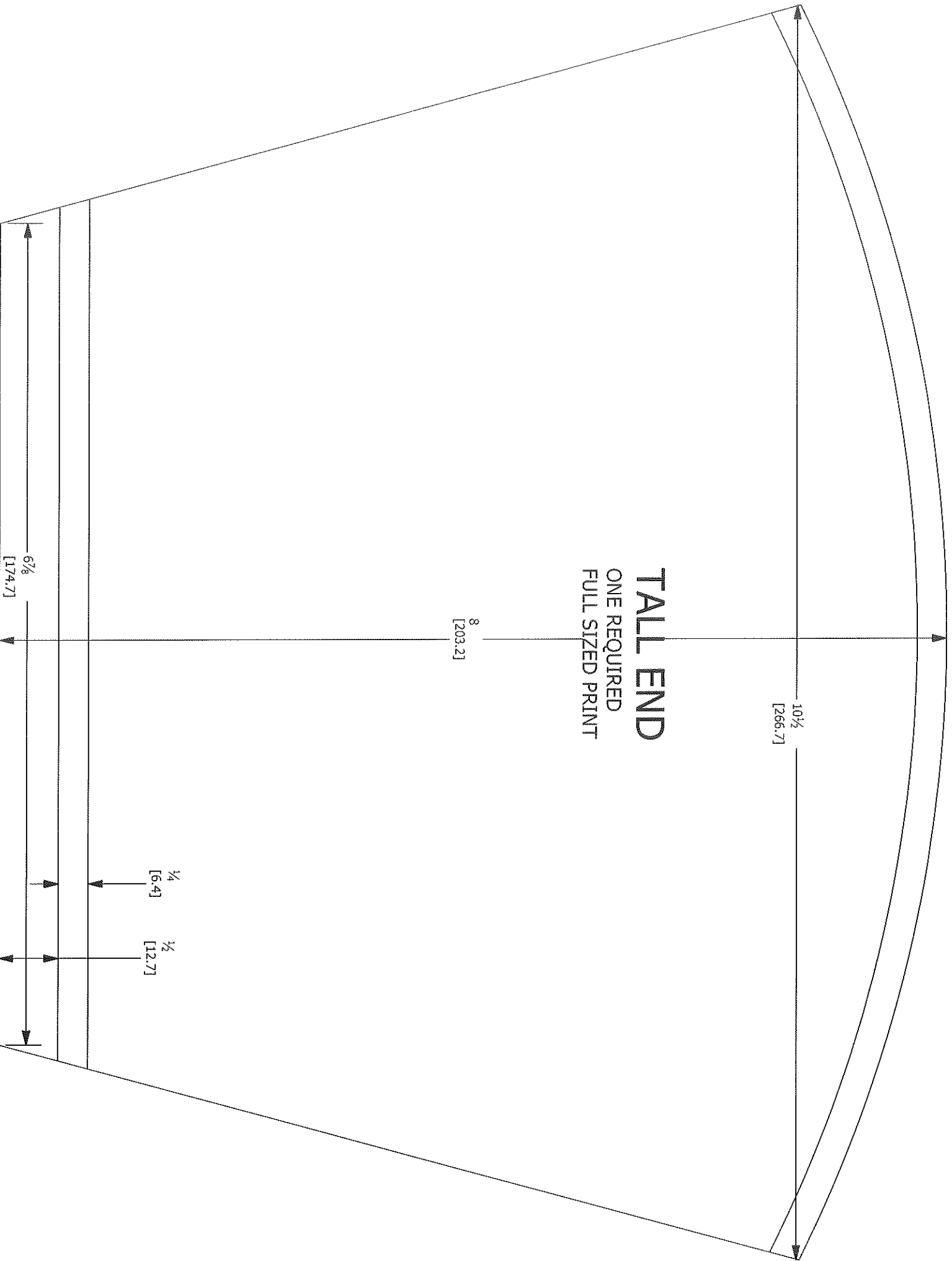

**TALL END**  
ONE REQUIRED  
FULL SIZED PRINT

$10\frac{1}{2}$   
[266.7]

$8$   
[203.2]

$\frac{1}{4}$   
[6.4]

$\frac{1}{2}$   
[12.7]

$6\frac{1}{8}$   
[174.7]

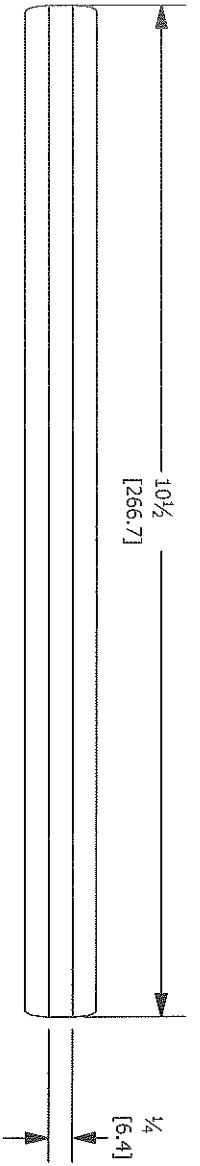

# TALL END

ONE REQUIRED

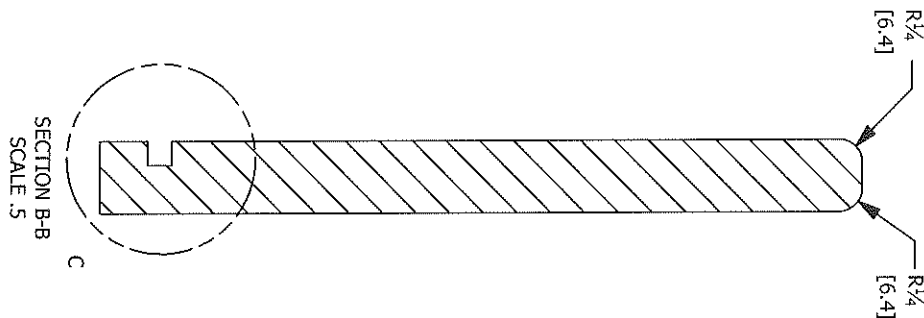
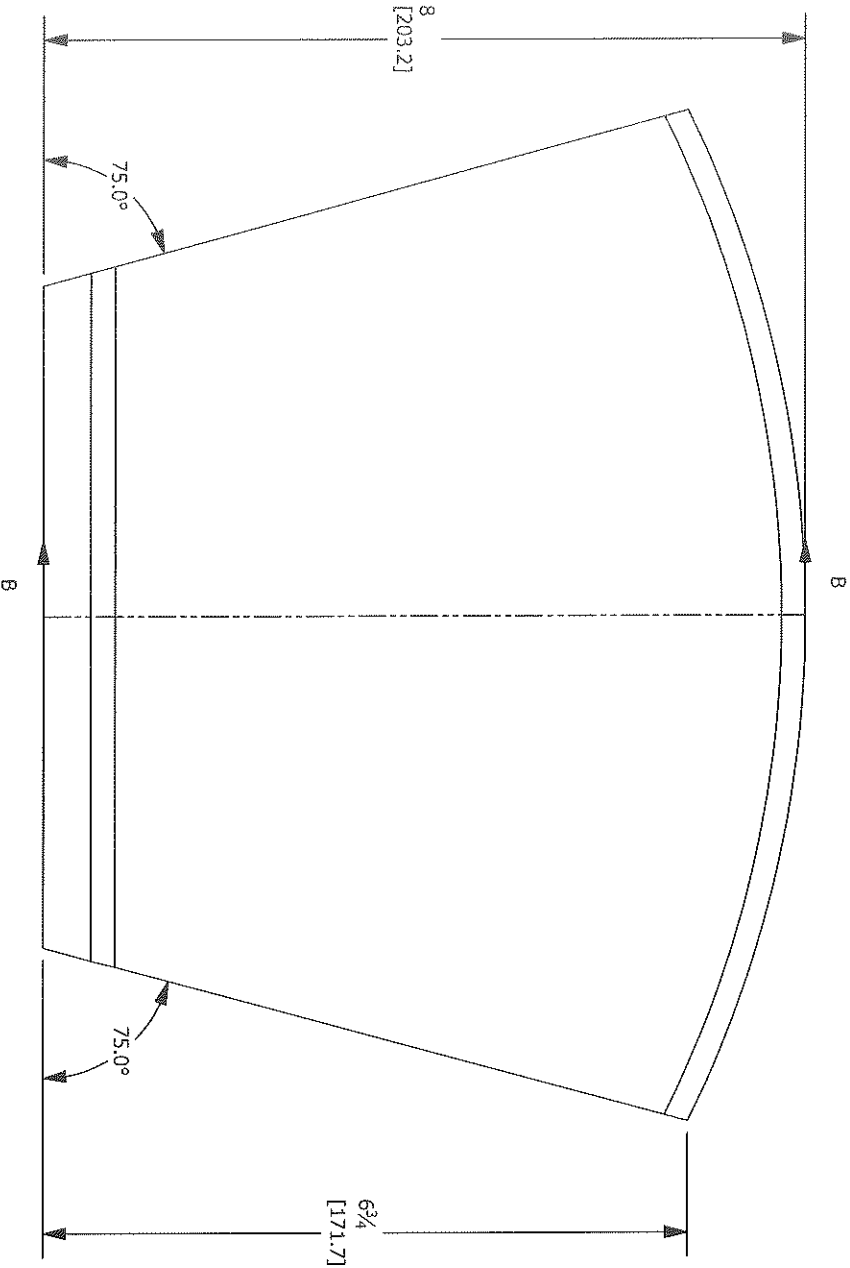
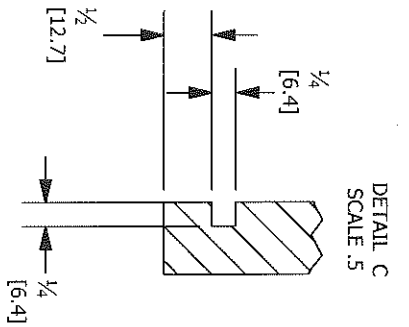

# SHORT END

ONE REQUIRED

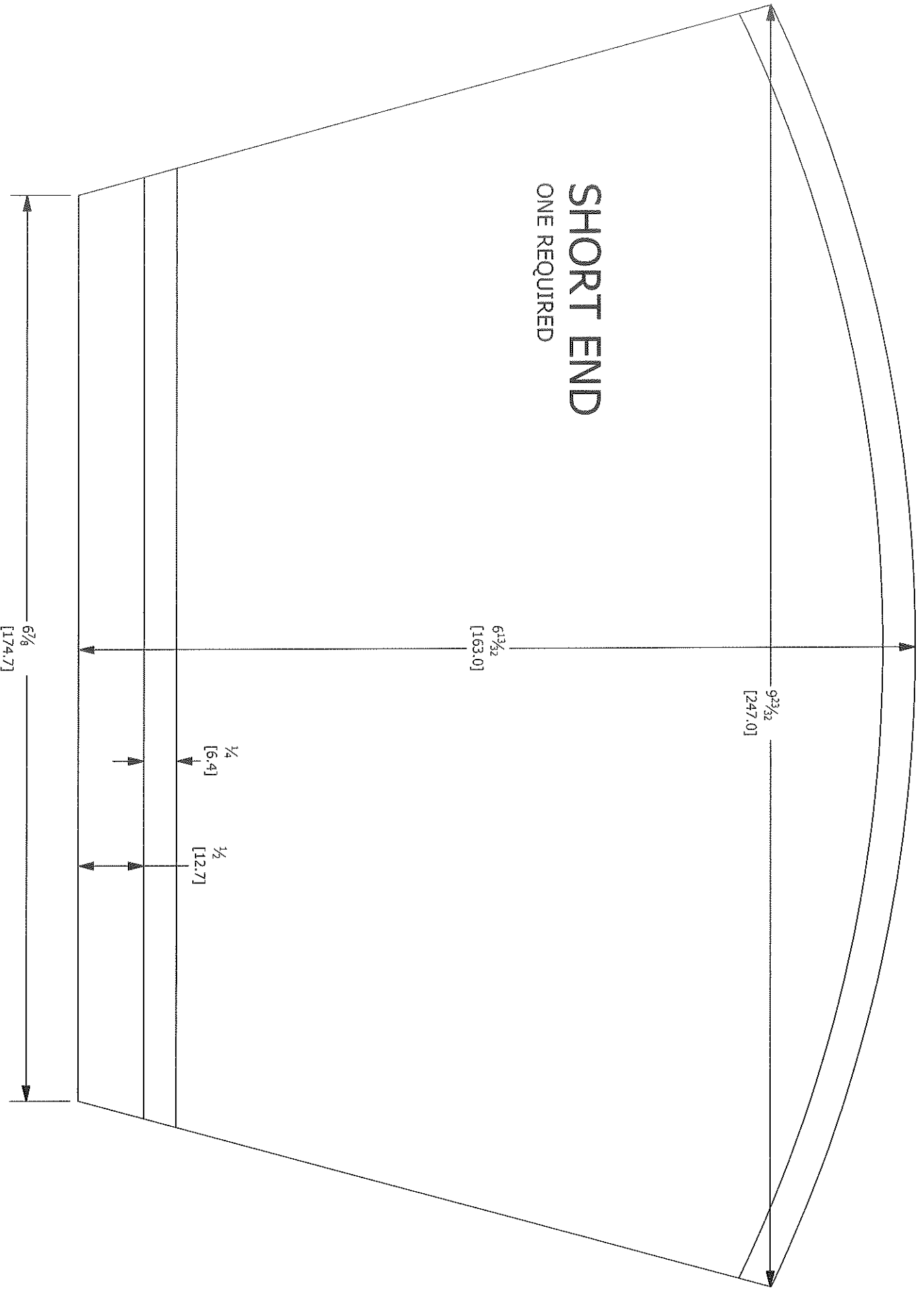



DETAIL E  
SCALE .5

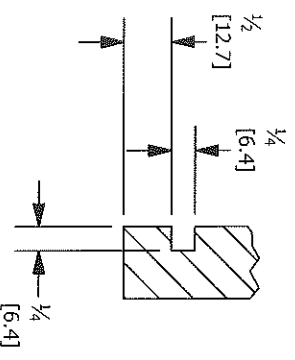
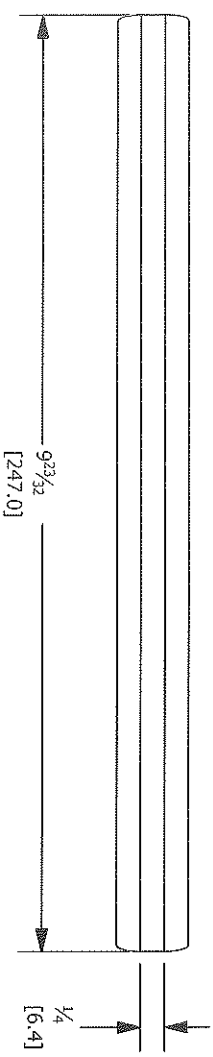

# SHORT END

ONE REQUIRED

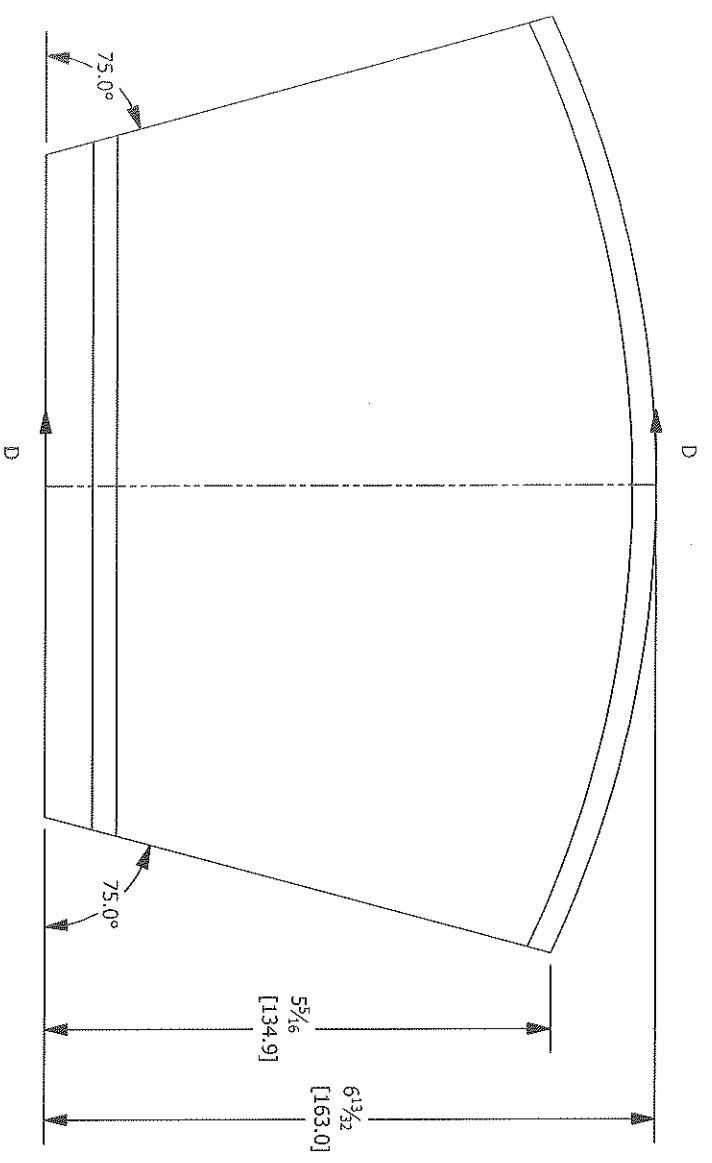

SECTION B-D  
SCALE .5

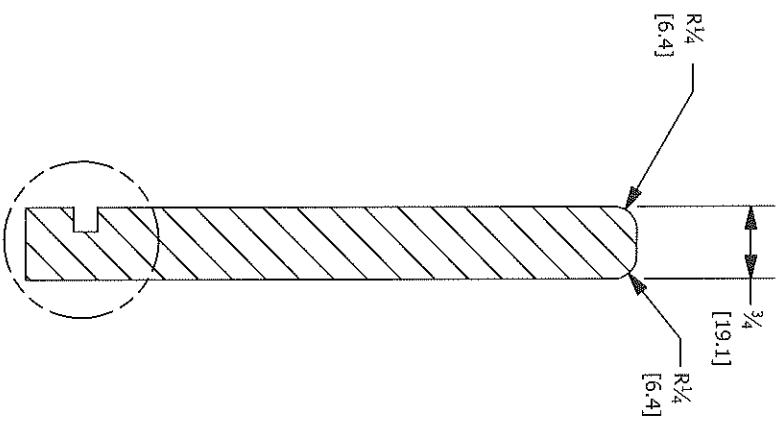

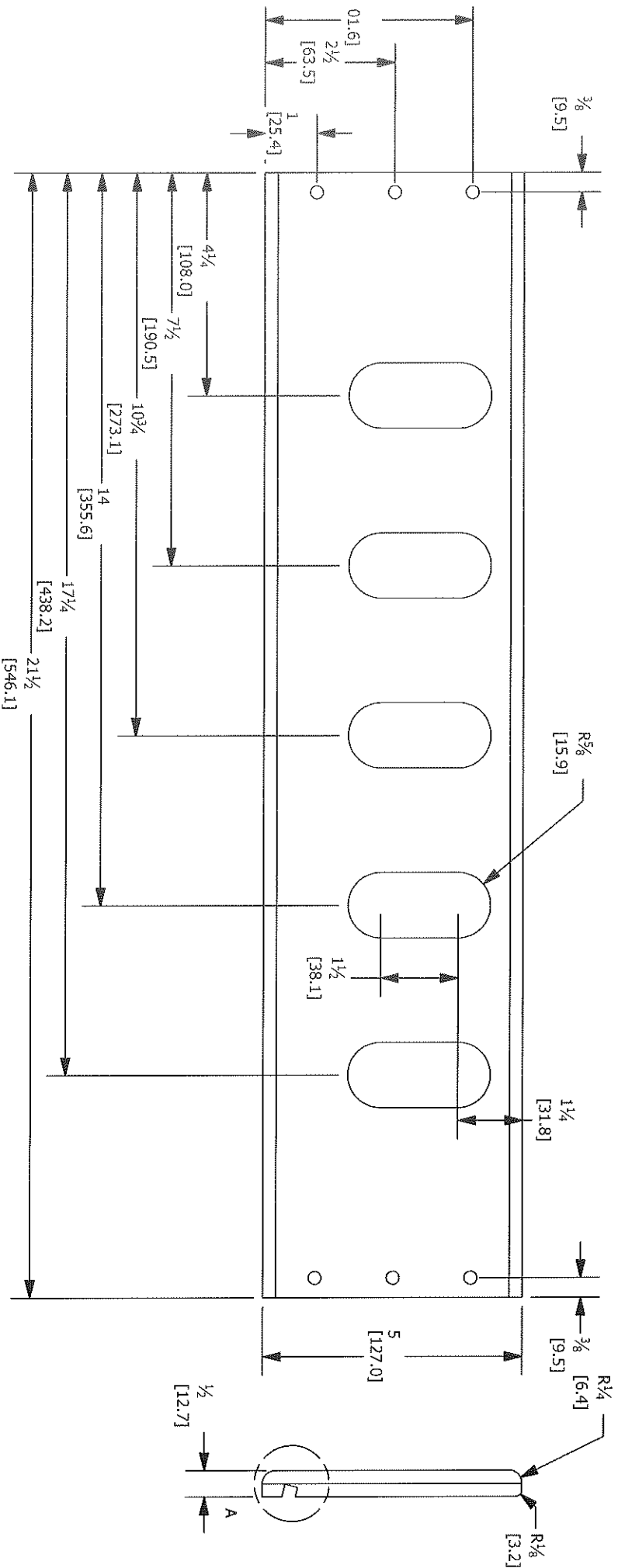

**SIDE VERSION 1**  
TWO REQUIRED

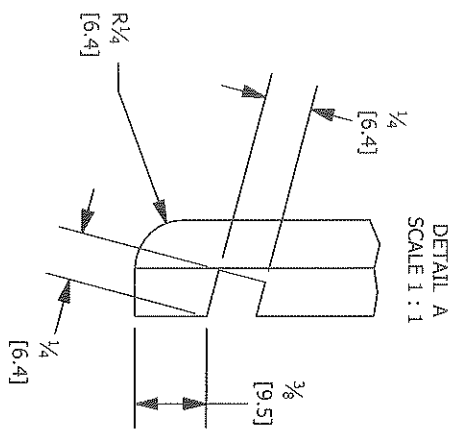

# SIDE VERSION 2

ONE LEFT AND ONE RIGHT REQUIRED

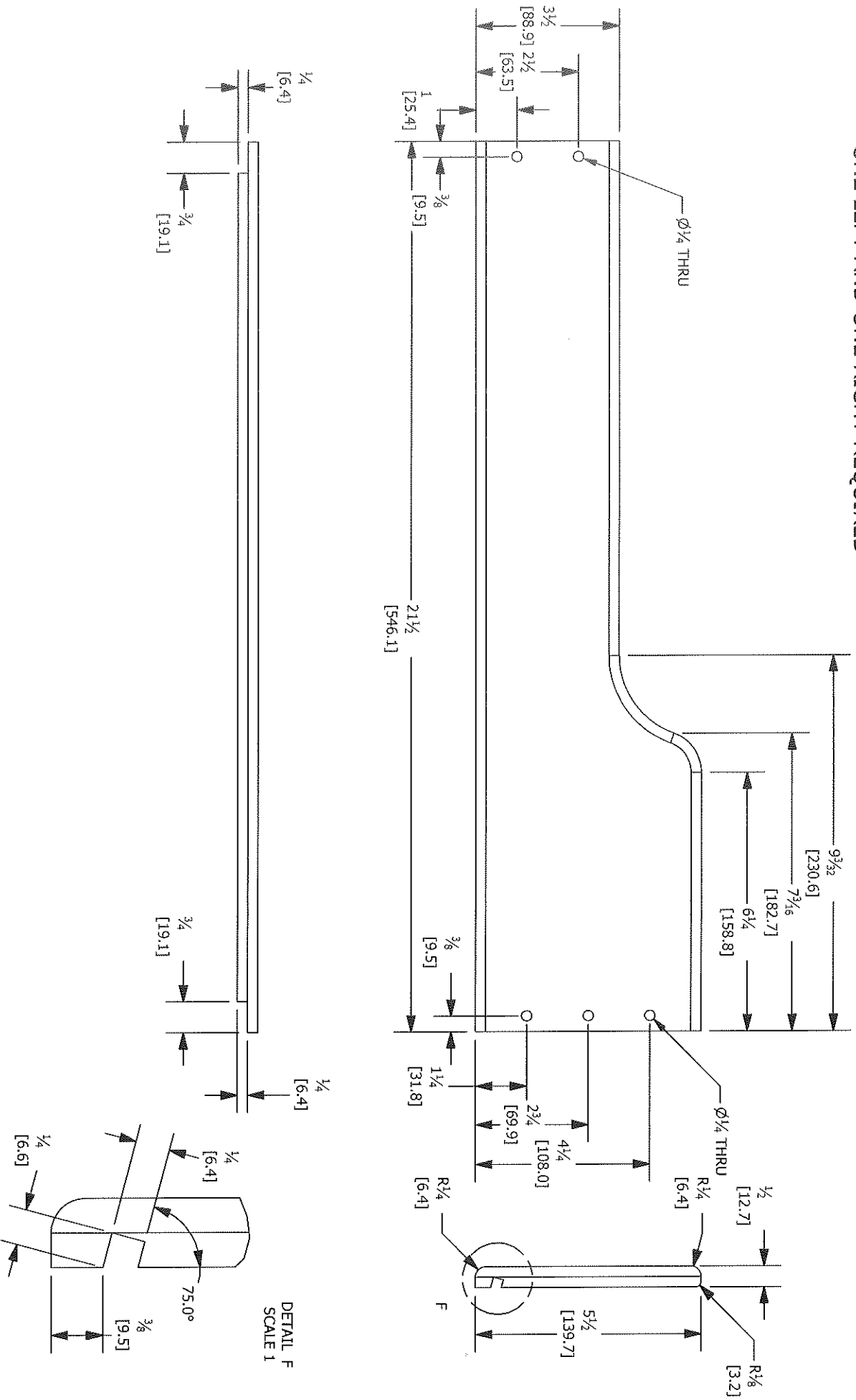

DETAIL F  
SCALE 1



**SIDE VERSION TWO**

CURVE DETAIL

FULL SIZE

REVERSE FOR LEFT SIDE

# ROCKER

TWO REQUIRED  
FULL SIZE PRINT

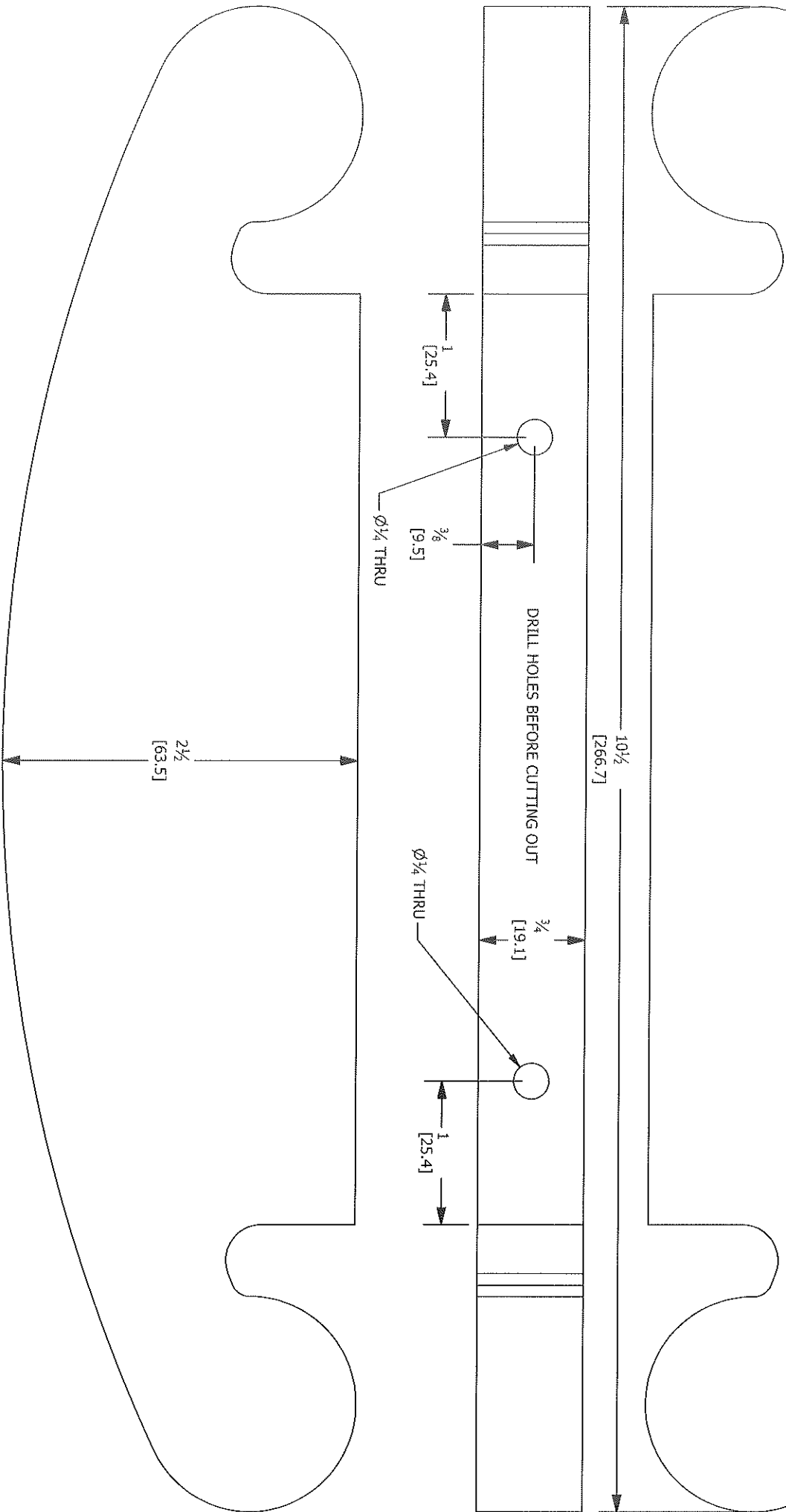

$7\frac{1}{6}$   
[179.4]

$\frac{1}{4}$   
[6.4]

$20\frac{1}{2}$   
[520.7]

**BOTTOM**  
ONE REQUIRED