



MANUAL

Manufacturing and Assembly of the Waterwheel Method A) – Laser Cutting

Overview:

Tools

- A.) Manufacturing of the module parts
- B.) Module assembly
- C.) Waterwheel assembly
- D.) Assembly of the coupling structure

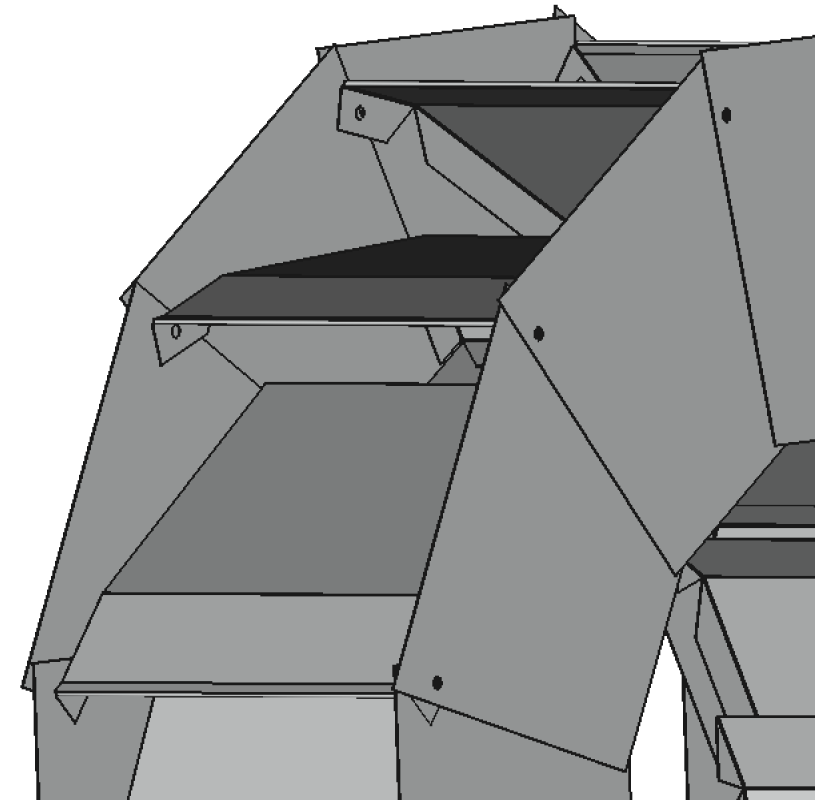

Introduction to the waterwheel concept

The waterwheel is an off-grid power generation system that can produce some 100 – 600W of 230V AC electricity. It is designed to fit the needs and circumstances of consumers in remote areas in Nepal suffering from energy poverty.

The concept is:

- **cheap** and **easy** to manufacture
- **flexible** – it is adaptable depending on the available water resource of the site (Head H and Flow Rate Q)
- **modular** – the water wheel consists of a variable number of standardized modules. The amount depends on the available head.
 - Low head (1,3m): 12 modules ↔ High head (2,3m): 25 modules
- **standardized** – the chamber modules are standardized, they are the same even for different available heads. The chamber modules are available in the widths of 20 and 30cm.

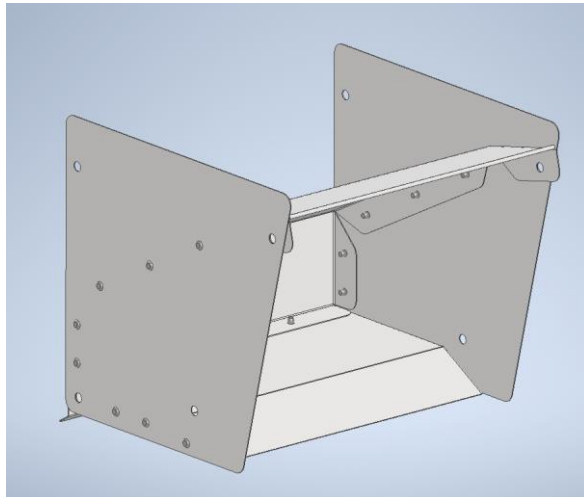

Standardized module

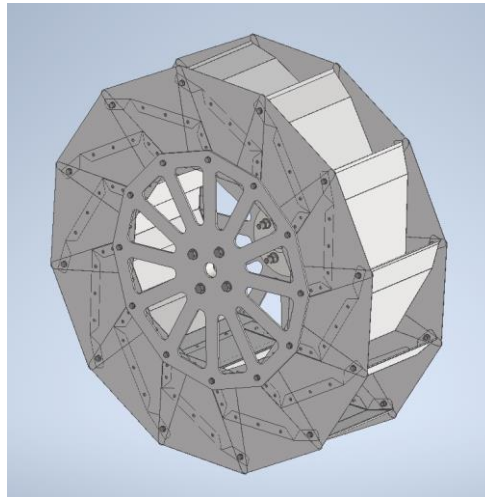

Waterwheel with 12 modules

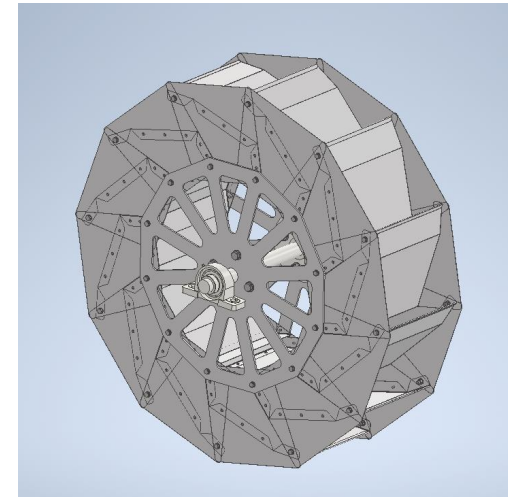

Finished water wheel assembly

Components of the System

Periphery
Intake & Canal

Hub
Shaft
Bearings

Support
Structure

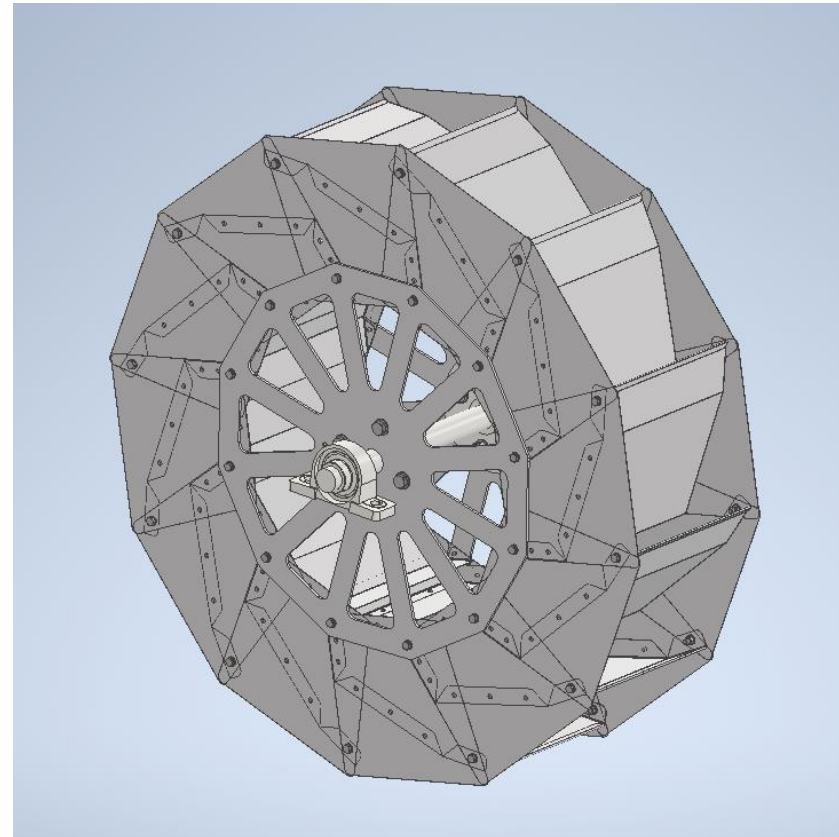

Transmission

Generator

Control System
Power Electronics
Consumers

Tools Needed for the Manufacturing of the Waterwheel



This manual explains the assembly of a 12 module waterwheel. The same principle and steps can be applied for all sizes. Please refer to the dimensioning tool to size your optimal system and adjust the amount of parts and tools as needed.



Rivet pliers with blind rivets

240 x 4mm blind rivets



Bolts, nuts & washers

24x M8-20mm bolts
24x M8-30mm bolts
8x M14-50mm bolts
2x M10-40mm bolts
24x M8 nuts
8x M14 nuts
72x M8 washers
16x M14 washers



Wrench

2x 13mm wrench
1x 16-17mm wrench
2x 22mm wrench



Rivet nut gun & rivet nuts

24x M8 rivet nuts

A.) Manufacturing of the module parts

1. Step: Laser cutting

Find the nearest and cheapest laser cutting and bending company and order the following parts for a 12 module waterwheel:

- 12x Bottom element
- 12x Paddle element
- 24x Wall element
- 2x Side plate

2. Step: Bending

If the Laser-cutting company does not bend the parts, follow steps 5) and 6) of section A.) in the manual for method B) using the unfolded parts

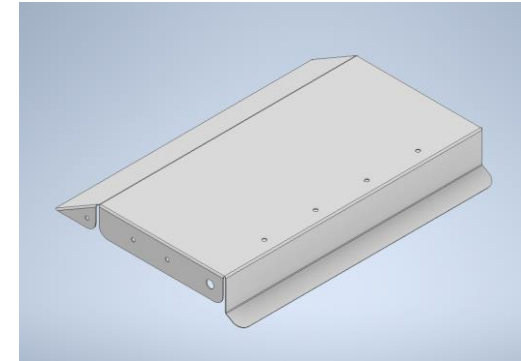

Bottom element

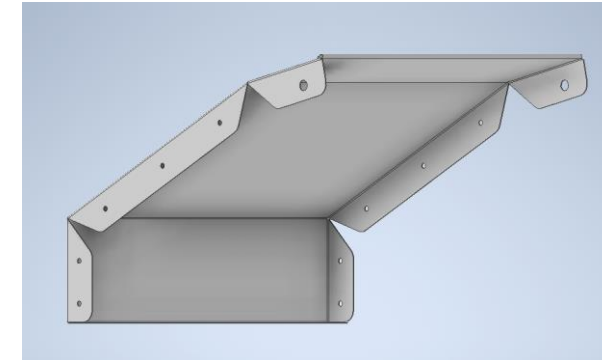

Paddle element

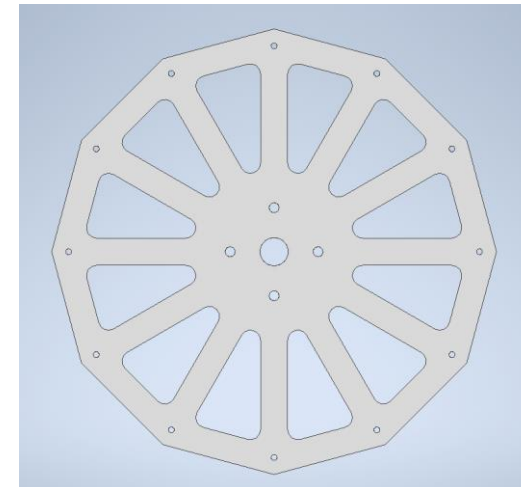

Side plate

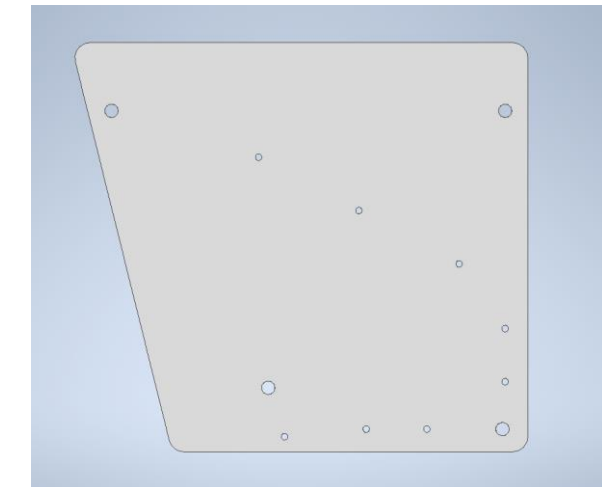

Wall element

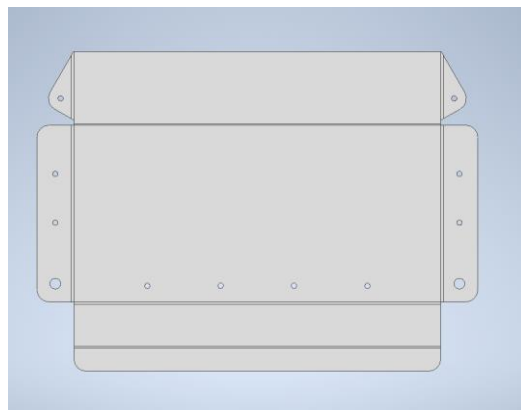

Bottom element unfolded

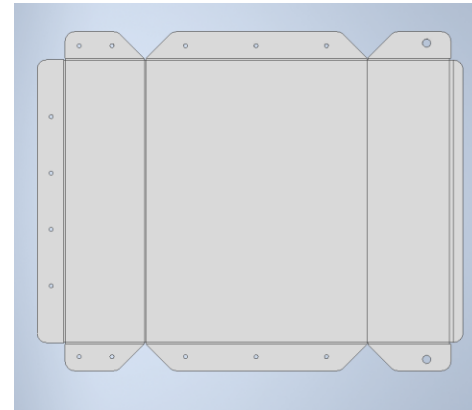

Paddle element unfolded

Note: See next slide to get the most out of one metal sheet

Getting the most out of your sheet

With this scheme you can get 13 modules out of two sheets of 4x8 feet

Note:
Part #3 is needed 2x per module.
That's why in the picture to the right, two parts of #3 are combined to one rectangle:

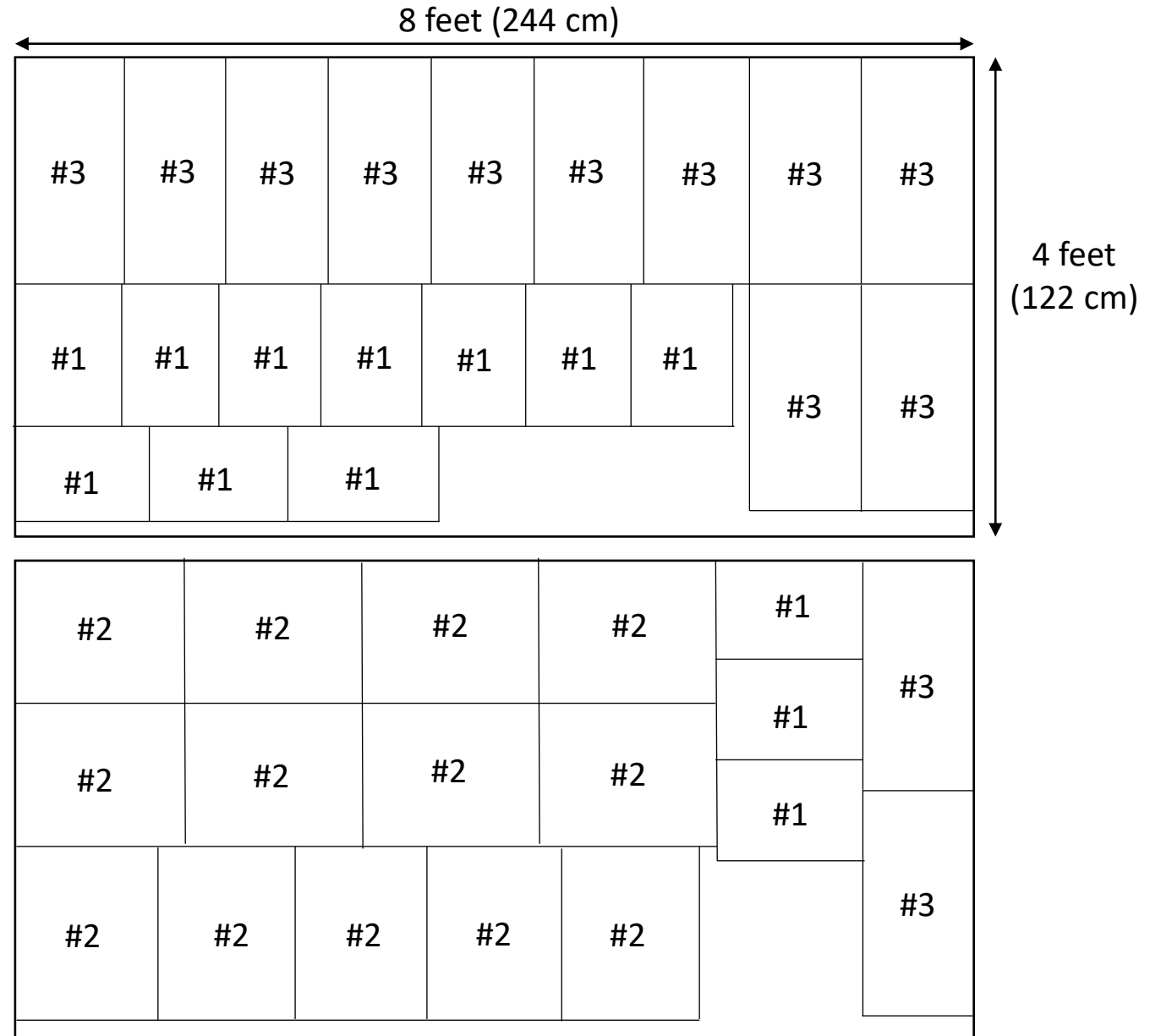
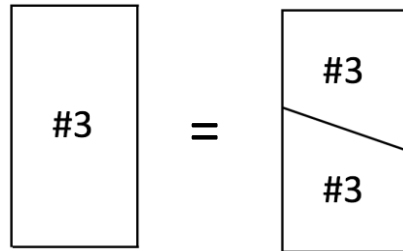

Result of section A.) Manufacturing the module parts

After completing section A.), all the single module parts for the waterwheel have been manufactured.



Now, in section B.) the parts are assembled together with rivets to complete modules.

The following parts are needed for each module:

- 1x bottom element
- 1x paddle element
- 2x wall element

B.) Module assembly

1. Step: Assembly of #1 & #2 (bottom and paddle elements)

Tools needed:

- Rivet plier
- 4x blind rivets per module

Overview

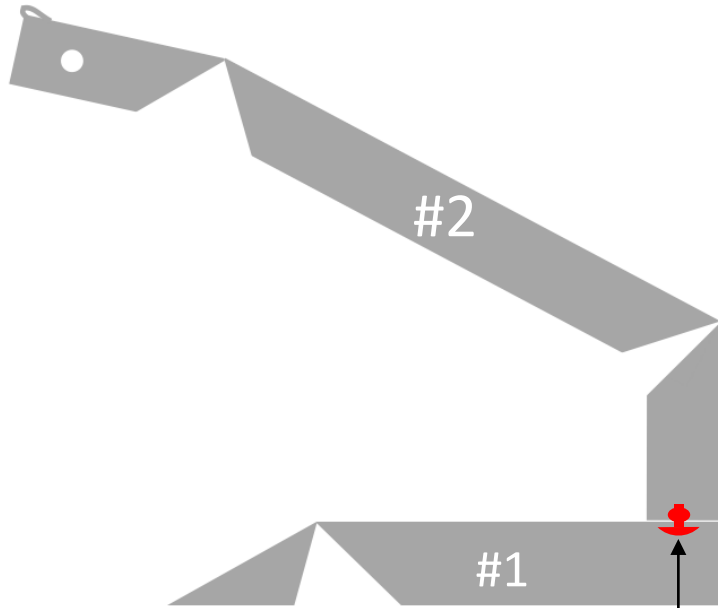

Rivet from the bottom (4x)!

Detail

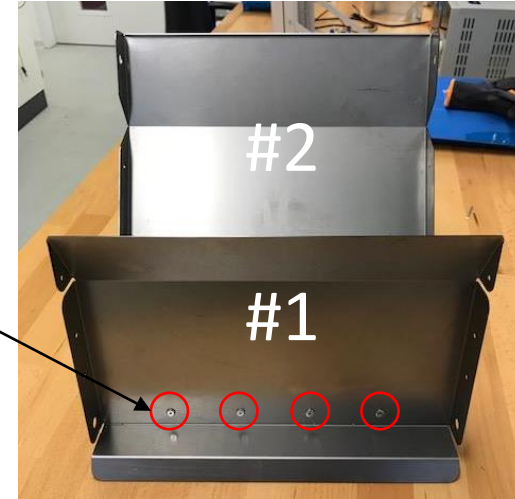

Rivet from the bottom (4x)!



2. Step: Assembly of #1/#2 and #3 (wall elements)

Tools needed:

- Rivet plier
- 8x blind rivets for each wall element
→ 16x rivets per module

Overview

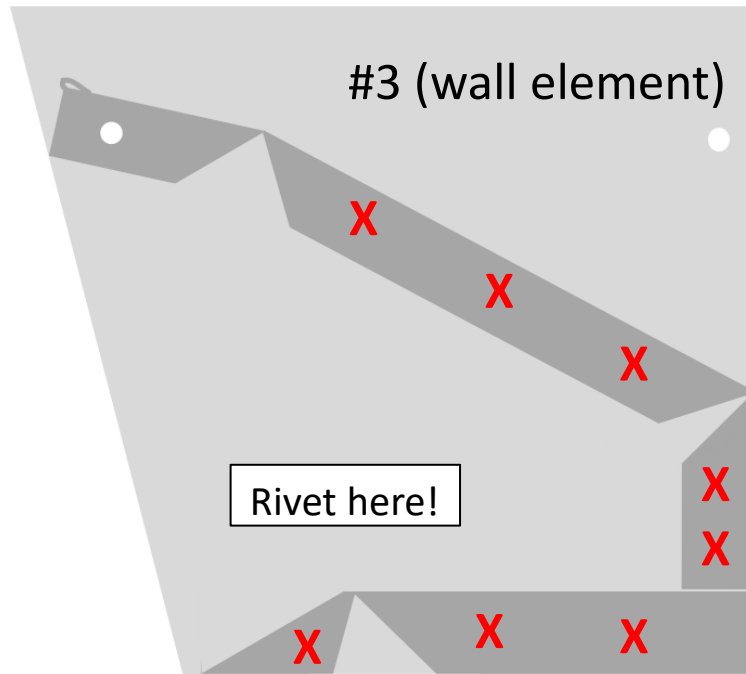

Steps

1. **Align** rivet holes



2. **Rivet** the parts together from the outside in

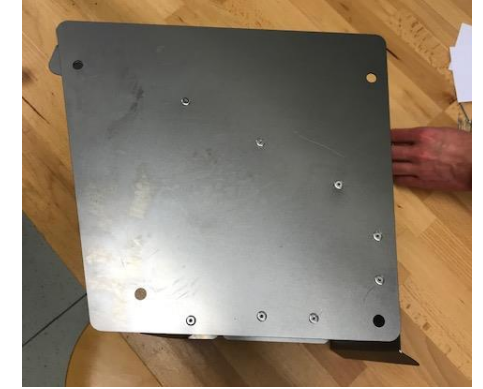
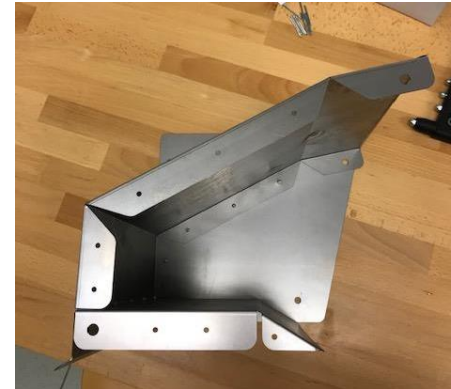

3. **Repeat** for the second wall element

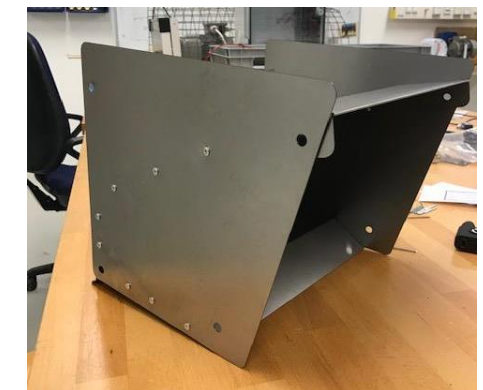

3. Step: Insert rivet nuts on #1

Tools needed:

- Rivet nut gun
- 2x rivet nuts per module

Overview

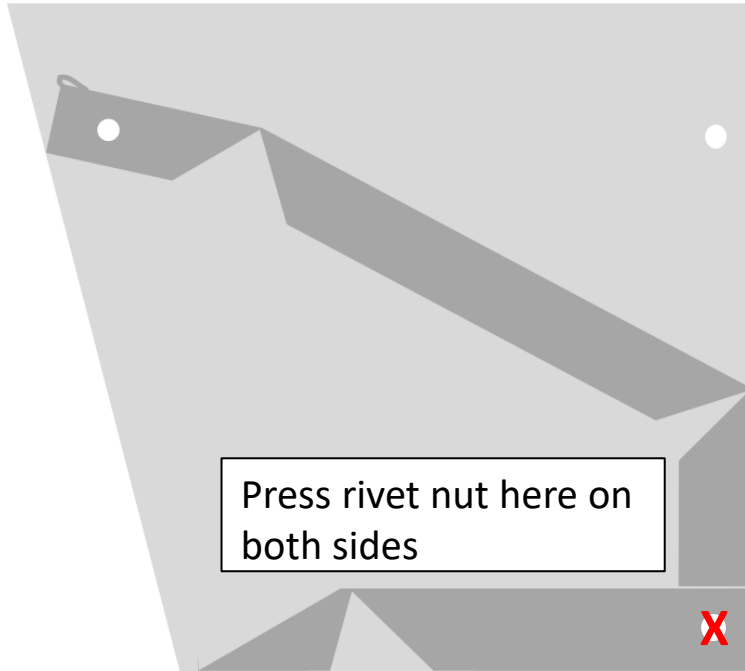

Steps

1. **Insert** rivet nut into rivet nut gun



2. **Insert** rivet nut gun from the outside into hole



3. **Apply** constant pressure to set rivet nut



4. **Repeat** on the other side

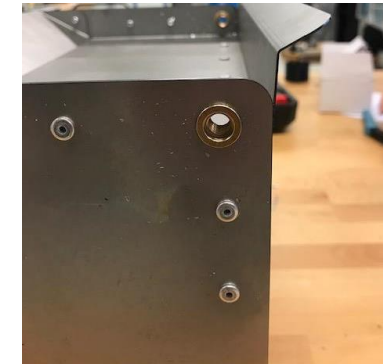

Method A)
Laser cutting

Result of section B.) Module assembly

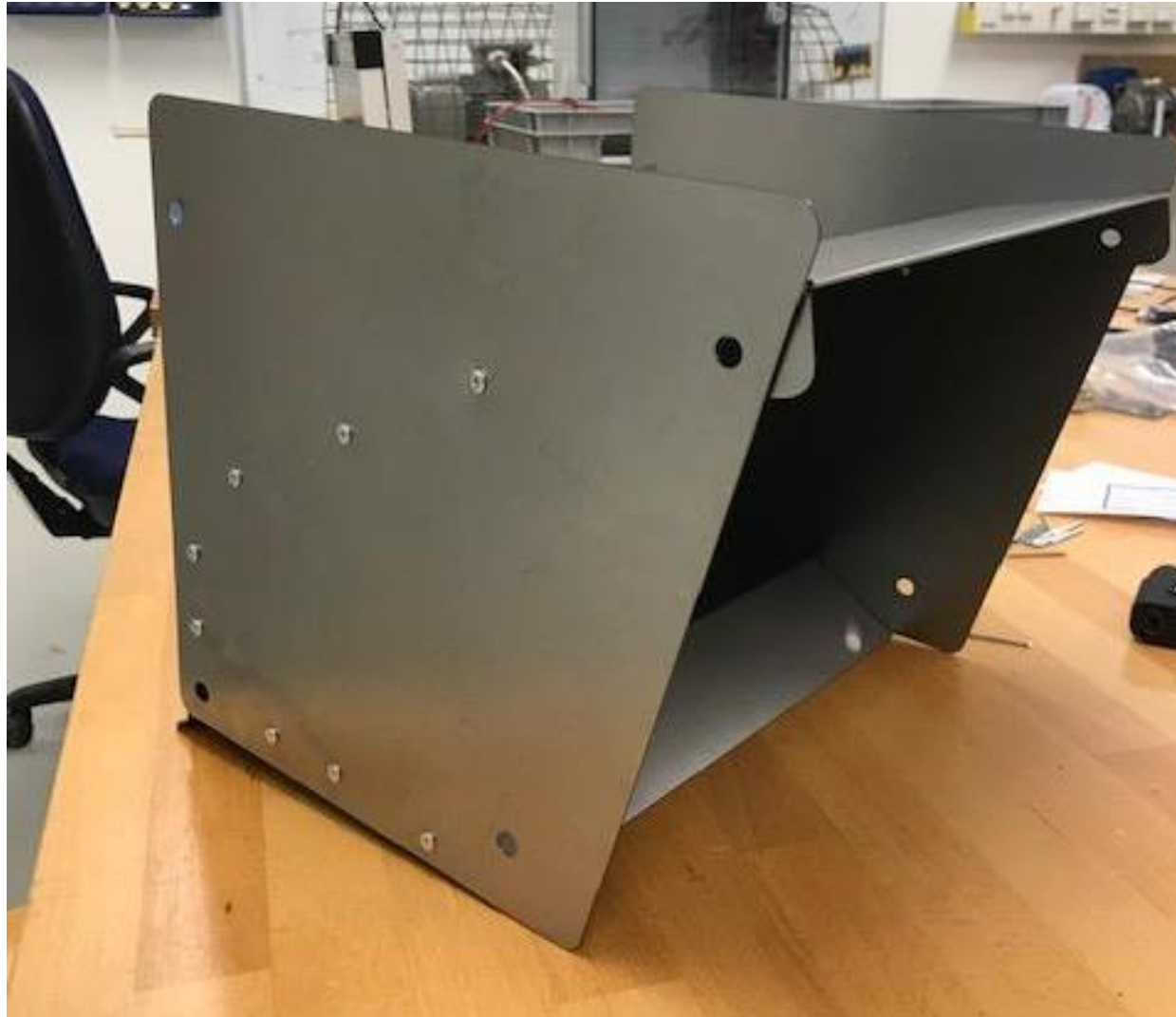

C.) Waterwheel assembly

1. Step: Rough positioning of two modules

Tools needed: none

Insert the modules into one another
as shown below!
Pay attention to the detail on the right!

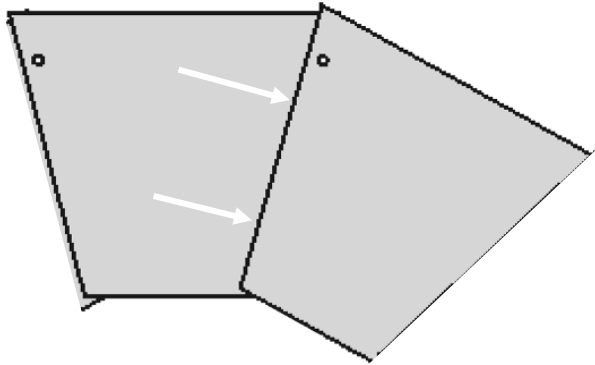

Module A is inserted into B.
B is inserted into C.

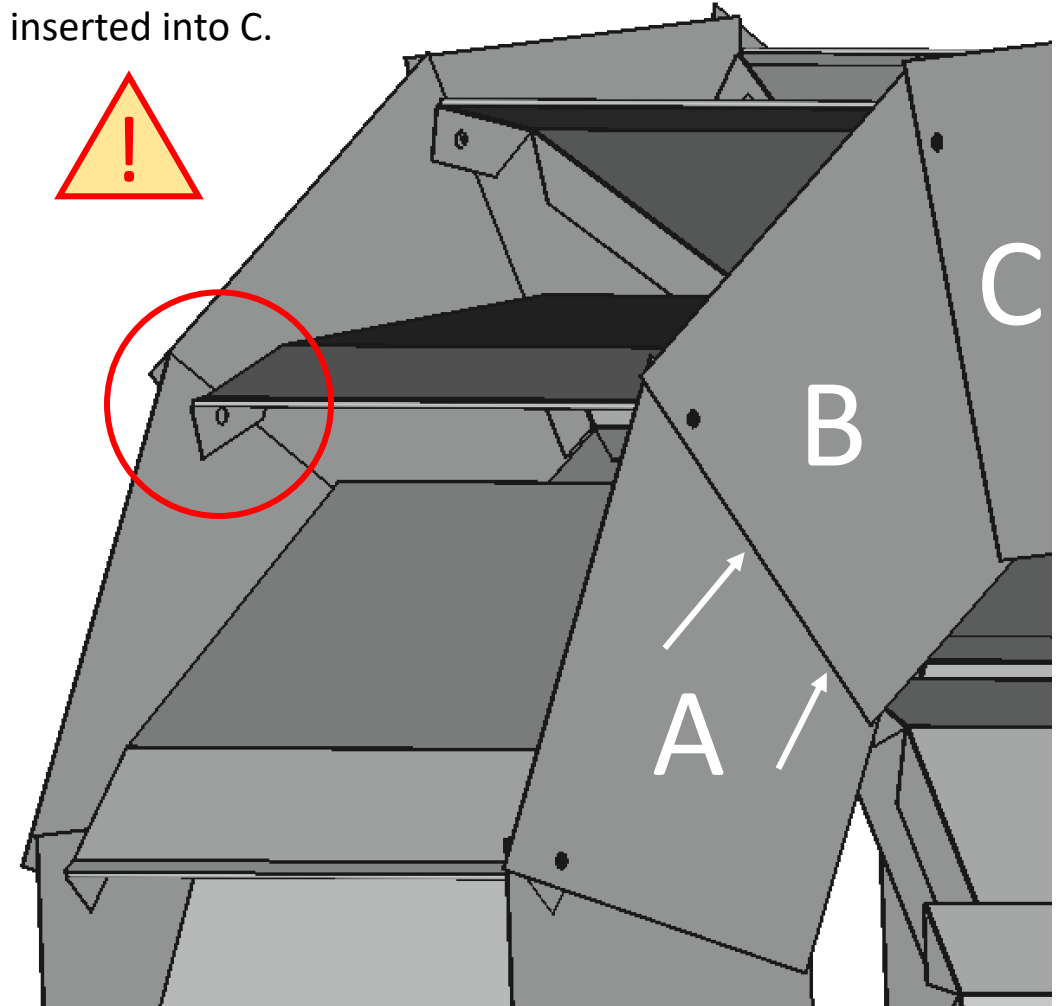

2. Step: Fixing the modules with the outer holes

Tools needed:

- 2x13mm wrench
- 24x M8 bolts (20mm length)
- 24x M8 nuts
- 24x M8 washers

Overview

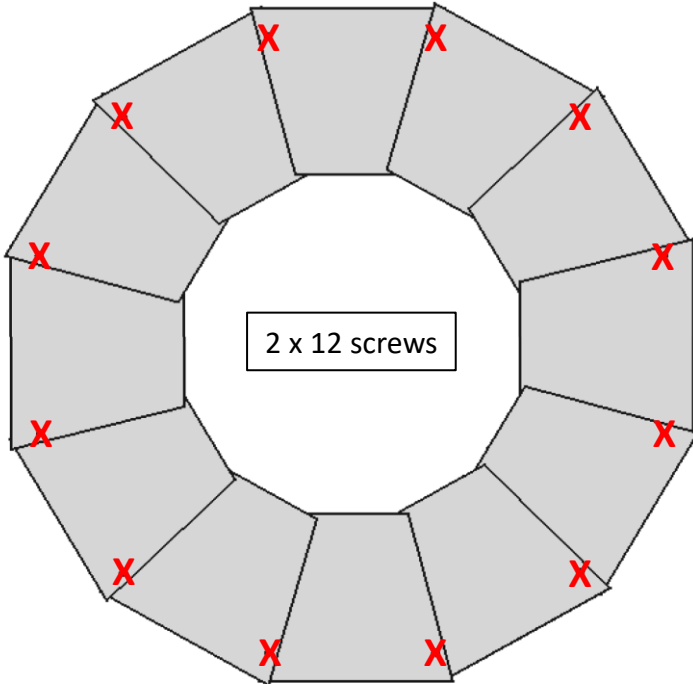

Steps

1. **Position** the modules so that the inner and outer holes are aligned
You may need to apply some pressure (shown with red arrows)



2. **Insert** fasteners (bolt, nut and washer) in the outer holes, but don't tighten them completely

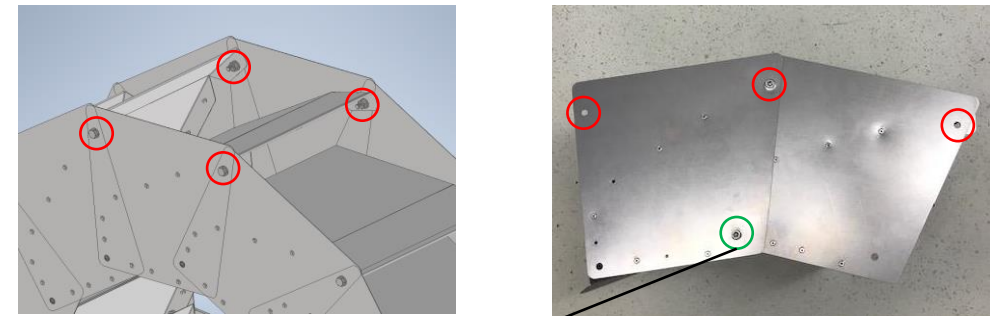

You may need to insert the M8 (30mm length) bolts on the inner module holes to keep their position fixed while you apply pressure

3. **Repeat** steps 1 and 2 for all the modules

3. Step: Fixing the side plates to the module arrangement

Tools needed:

- 2x13mm wrench
- 24x M8 bolts (30mm length)
- 24x M8 washers

Overview

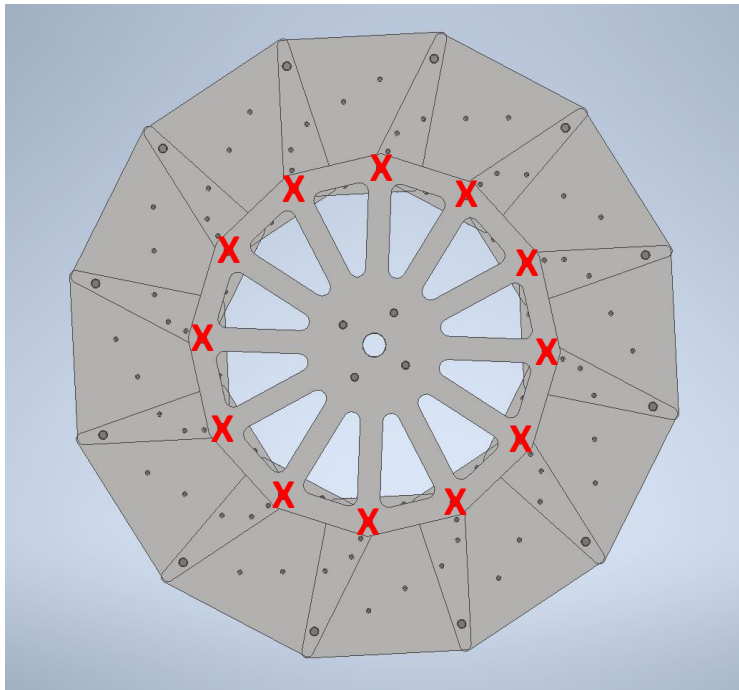

Steps

1. **Place** the side plate on top of module arrangement and align the outer side plate holes with the inner module holes



2. **Insert** fasteners (bolt and washer) into rivet nuts from step B-3) but don't tighten them completely



If you inserted the M8 (30mm length) bolts in the inner module holes in step 2: Remember to remove them before placing and fixing the side plate on top of the modules



3. **Flip** the wheel and **repeat** steps 2 and 3 on the other side (the alignment should be easy now)

Method A)
Laser cutting

Result of section C.) Waterwheel assembly

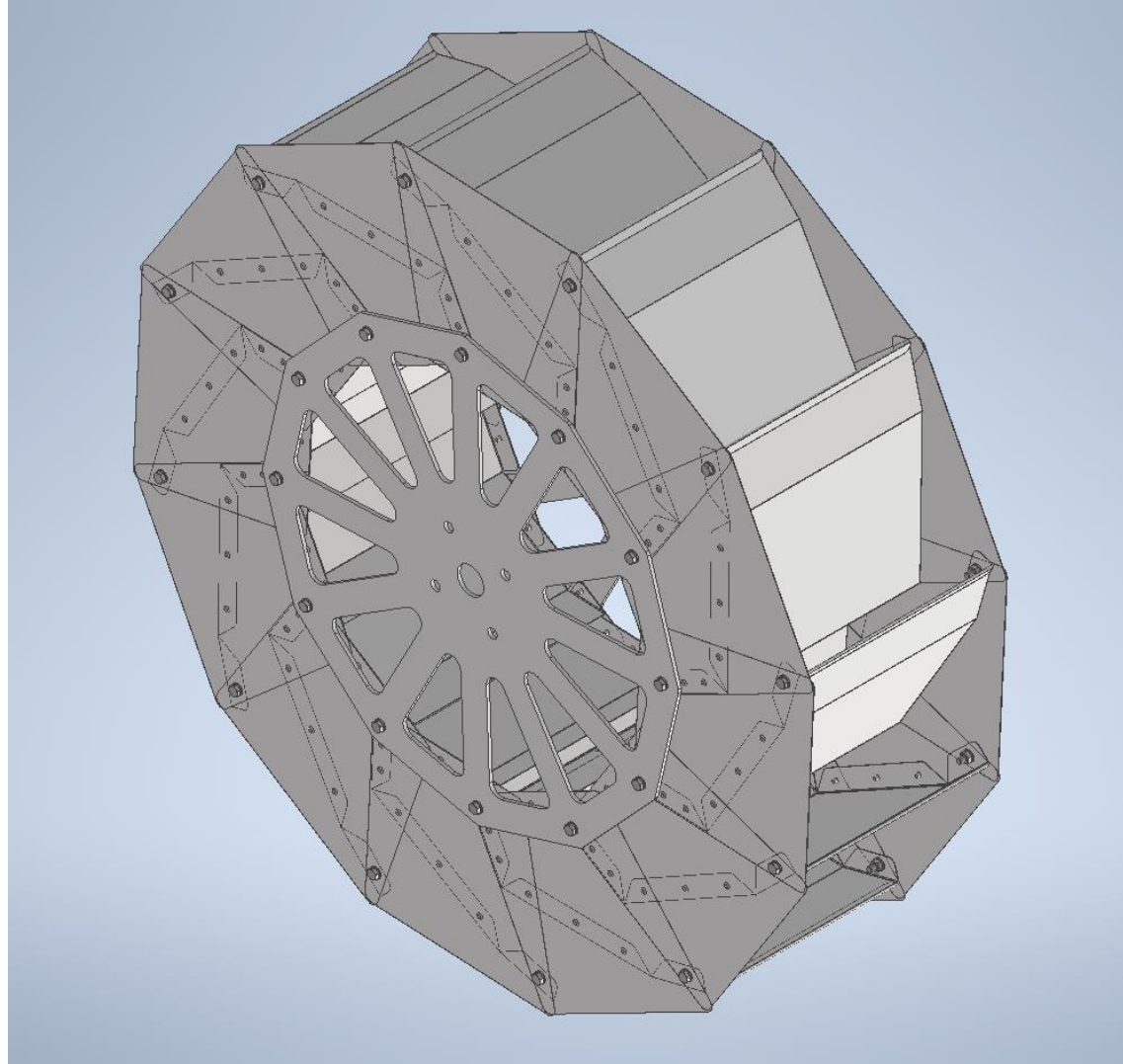

D.) Assembly of the coupling structure

1. Step: Connect flange

Tools needed:

- 2x Flange
- 8x M14 bolts (50mm length)
- 8x M14 nuts
- 16x M14 washers
- 2x 22mm wrench



- There are two types of readymade parts that were found in Nepal to be usable as hubs: belt drive pulleys (cast iron) and chain sprockets (forged steel)
- Belt drive pulleys have a good availability and lower price. However, the forged steel of the sprockets is a more solid and durable material.
- If chain sprockets and belt pulleys do not serve the specific purpose or are not available at your location, manufacture custom-made hubs out of brass or mild steel



Chain sprocket

Belt pulley

Detail

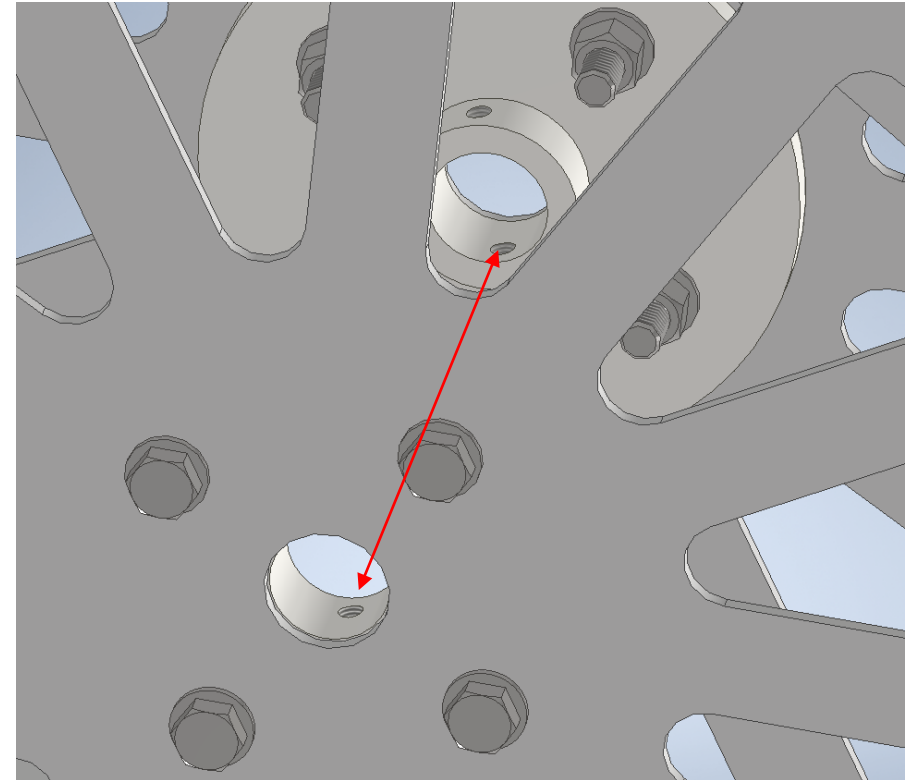

1. Flanges are placed on the inside of the waterwheel to reduce its width
2. Set screws/keyways have to be aligned

2. Step: Fix waterwheel to shaft

Tools needed:

- 2x M10 set screw (40mm length)
- Shaft
- 1x 16-17mm wrench



- Important: use solid shafts and not hollow ones due to the high torsion acting on it
- Options in Nepal: 40mm readymade shaft out of C45 steel (includes holes for set screws) OR 60 and 80mm mild steel shaft (needs to be straightened with a hydraulic press, turned to 60 or 80mm on a lathe and fabricated with keyways and set screw holes)
- If you choose the materials described, you will retain a minimum safety factor of $S \geq 3$ for all wheel sizes.

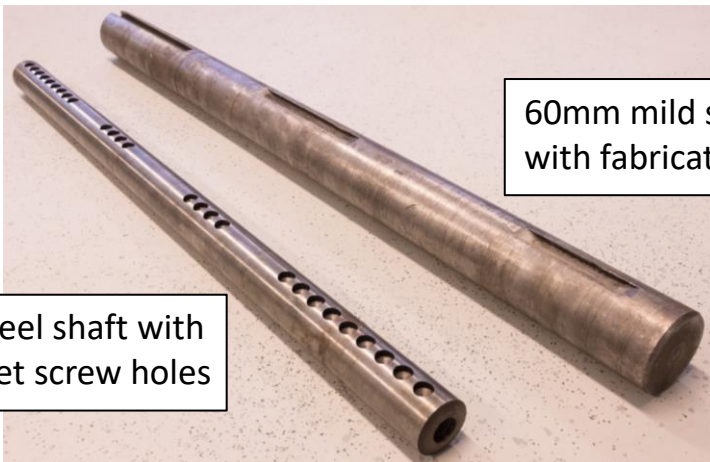

60mm mild steel shaft
with fabricated keyways

40mm C45 steel shaft with
readymade set screw holes

Steps

1. **Insert** shaft into waterwheel



2. **Align** set screw hole from flange with set screw hole from shaft



3. **Fix** shaft to waterwheel with M10 set screw on both sides



Be aware that the provided shaft designs include holes for different system widths (for ex. 20cm waterwheel width)
Make sure to fix your waterwheel to the correct holes

Overview

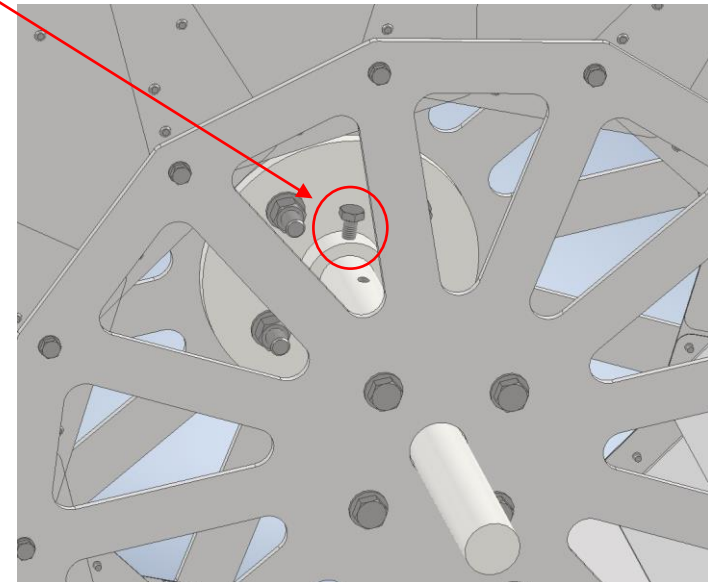

3. Step: Connect assembly to bearings

Tools needed:

- 2x UCP 208 bearing

Overview

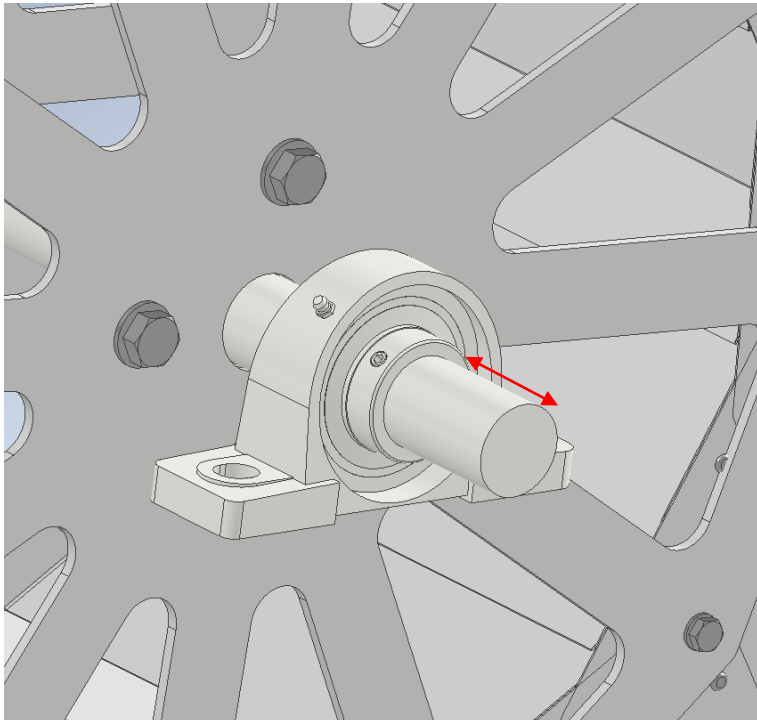

Steps

1. **Insert** shaft into bearings on both sides



2. **Fix** shaft to bearings using set screws



3. **Align** the bottom plane of the bearings to each other



Leave enough shaft space outside of the bearing to connect the system to the generator

Method A)
Laser cutting

Result of section D.) Assembly of coupling structure

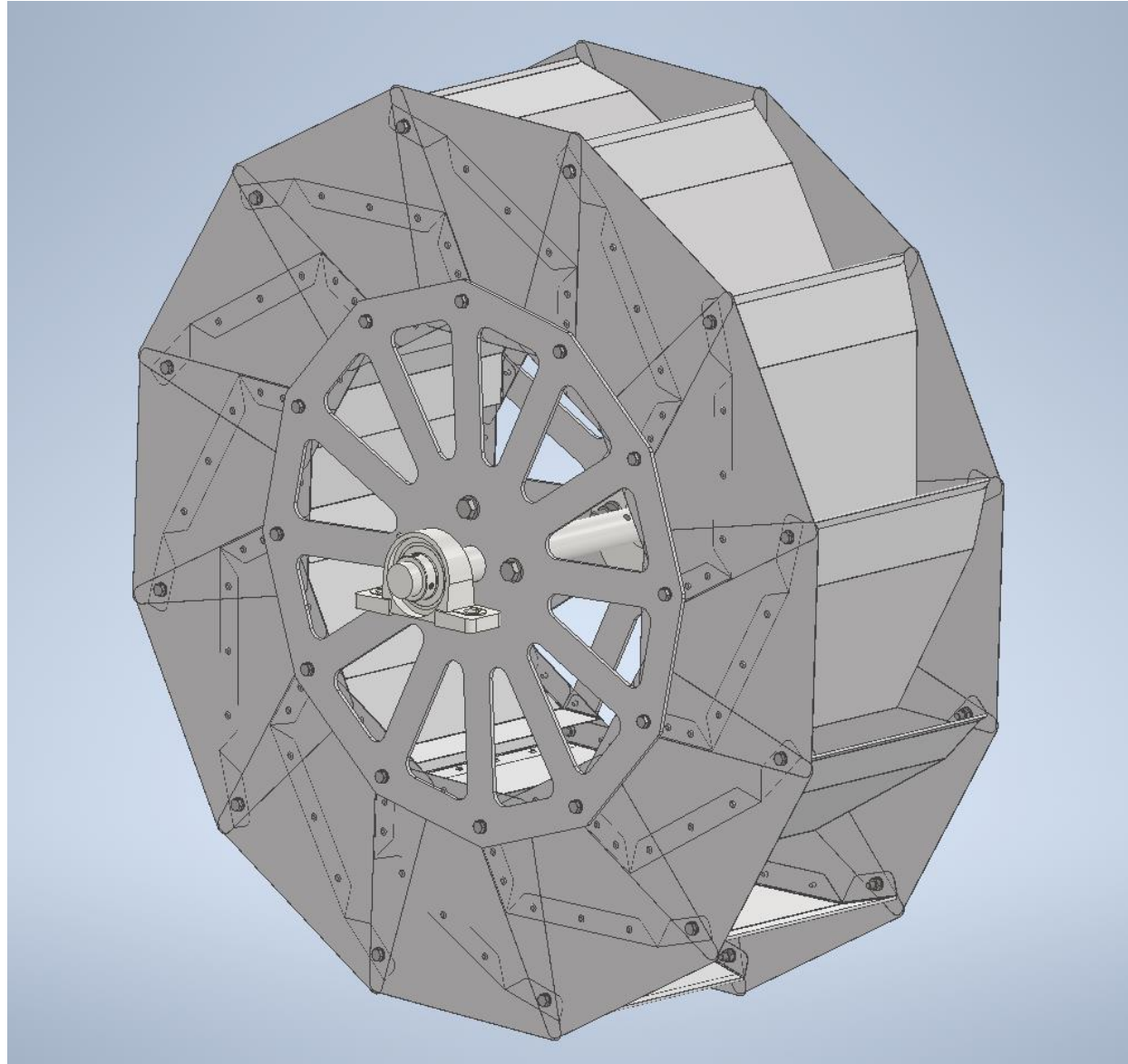



MANUAL

Periphery Components

Overview: Sections

Support structure

Foundation

Intake

Canal

Chute

