

Step 7: Design for 3D printing

After installing Solidworks ,which is a mechanical design automation application that lets designers quickly sketch out ideas, experiment with features and dimensions, and produce models and detailed drawings.I start by taking the camera measures and then continue with the modeling in Solidworks.

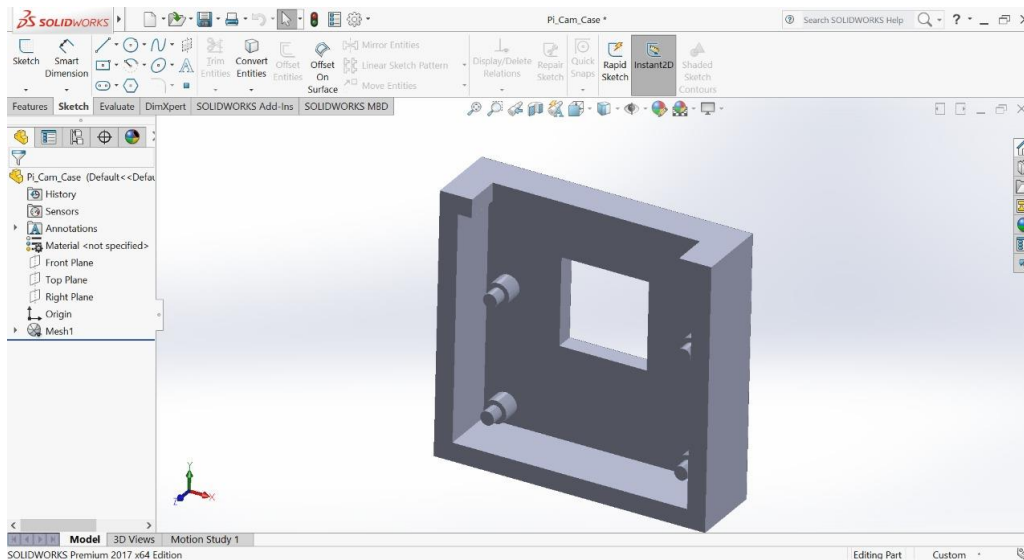

Before sending the file box in to the 3D ,we need to export to .stl File.

I'll use XYZware Software

