

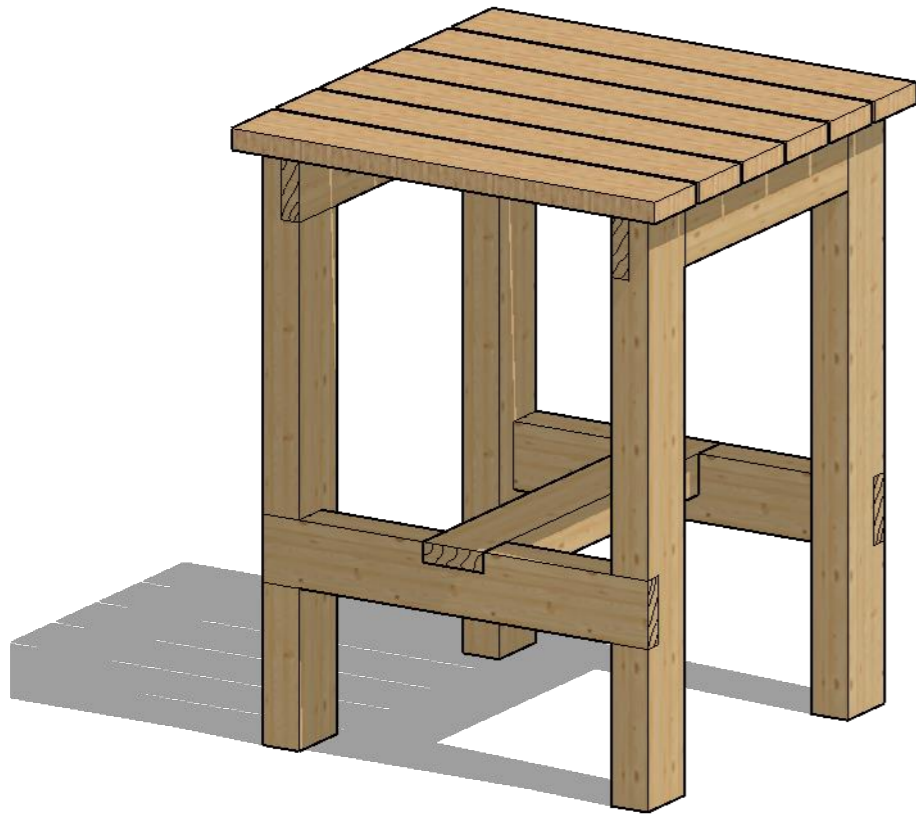

PROJECT TITLE





You will need the following to create this:

- Pencil
- Tape measure
- \*Try square
- \*Marking gauge
- 25mm or wider bevel edge chisel
- Claw hammer or mallet
- Tenon or panel saw
- Smoothing Plane
- Cordless drill- 3mm HSS pilot bit-countersink bit
- Number 2 Pozi drive screwdriver
- 8 x 4 x 30mm Pozi drive screw
- 8 x number 4 x 40 mm Pozi drive screws
- 24 x 40mm oval or lost head nails
- PVA glue or other equivalent
- Workbench or saw stool
- Vice or clamp

\* If you do not have access to a marking gauge and a Try square you can use a combination square.

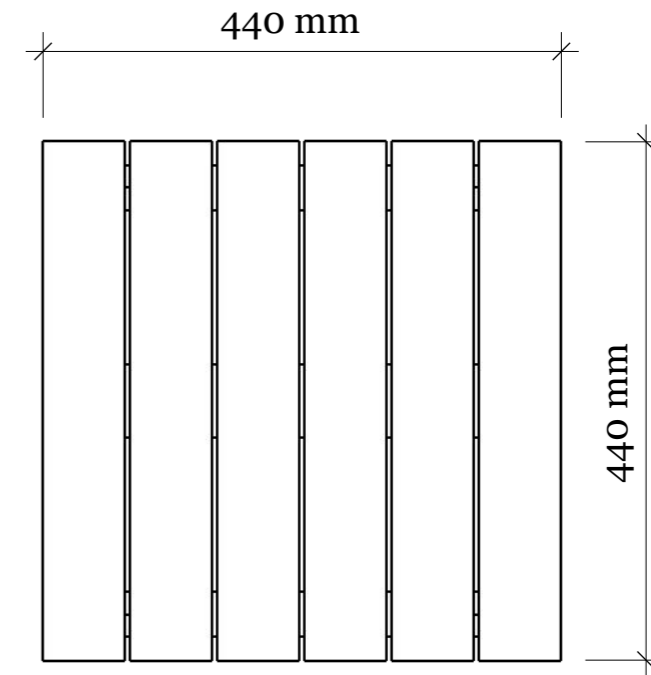
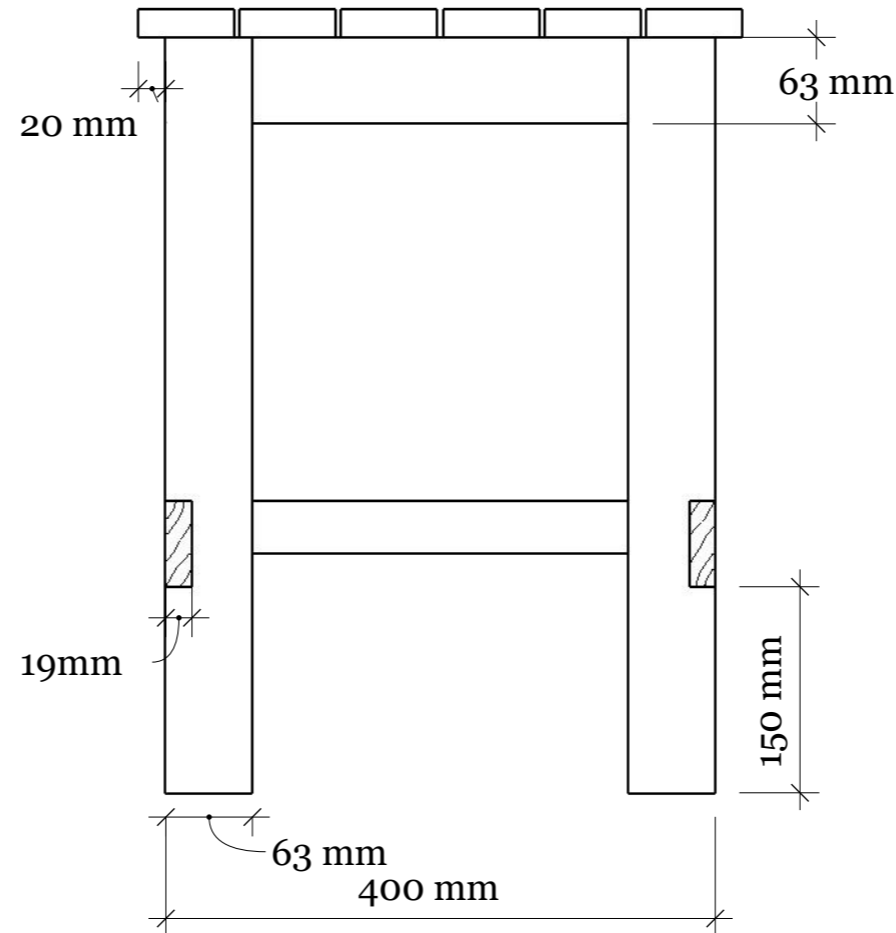
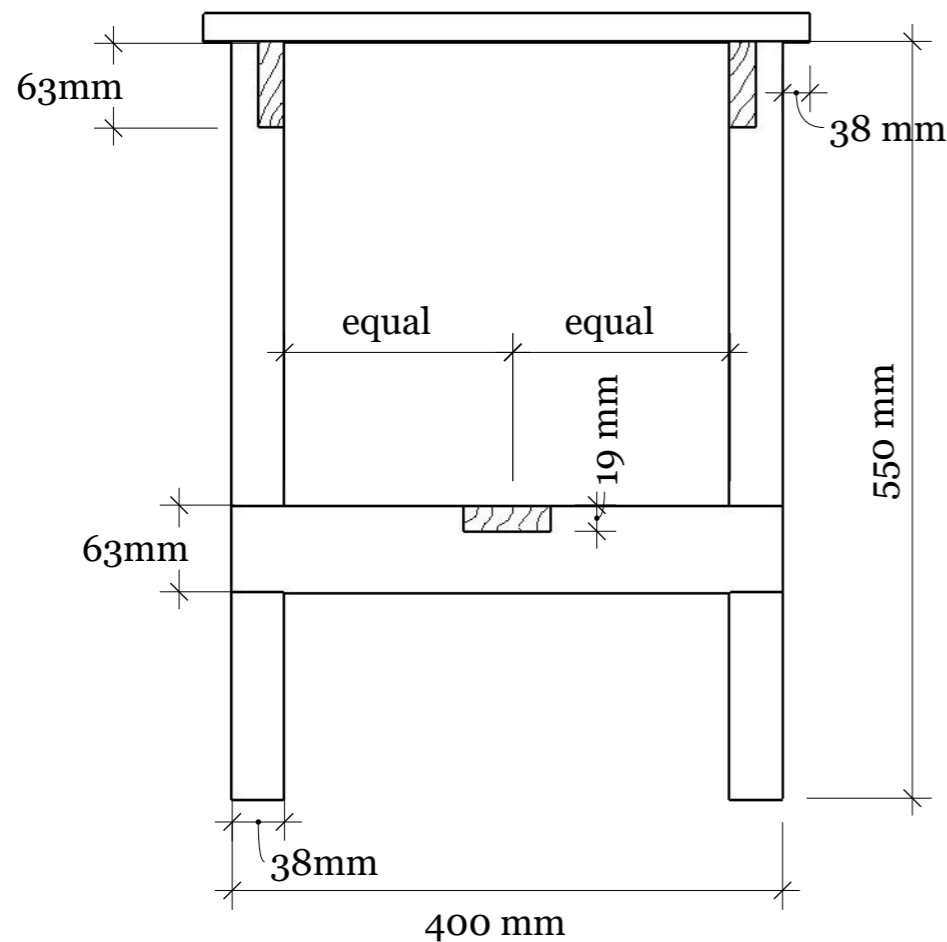

Table top slats are made from pallet timber but any suitable timber can be used.

REVISIONS		REMARKS
MM/DD/YY	05/22/20	Drawn by Craig Leach
1		...
2		...
3		...
4		...
5		...

